



2/4 Channel Class AB Amplifier

Model :

DA 2.175SQ

DA 4.120SQ

**Owner's Manual and
Installation Guide**

SPECIFICATION

MODEL	DA 2.175SQ
Supply Voltage	11~15V DC
Power Output @ 4 Ohm	175W X 2
Power Output @ 2 Ohm	250W X 2
Bridge Output @ 4 Ohm	400W X 1
Frequency Response	20Hz~22KHz(-3dB)
Signal To Noise Ratio	100dB
Input Impedance	20K Ohm
Input Sensitivity	250mV~4V
T.H.D.	<0.05%

MODEL	DA 4.120SQ
Supply Voltage	11~15V DC
Power Output @ 4 Ohm	120W X 4
Power Output @ 2 Ohm	180W X 4
Bridge Output @ 4 Ohm	300W X 2
Frequency Response	20Hz~22KHz(-3dB)
Signal To Noise Ratio	100dB
Input Impedance	20K Ohm
Input Sensitivity	250mV~4V
T.H.D.	<0.05%

INSTALLATION

Thank you for purchasing car audio amplifier. This Power amplifiers has been designed to provide highest performance with minimum maintenance.

However, its performance will only be as good as the care and quality of components with which is installed. We therefore advise that you read these instructions very carefully to familiarize yourself with the product and its features.

Before installing the power amplifier please read this instruction manual carefully. The instructions for mounting and connecting the set have to be followed precisely. If necessary, certified installer should be consulted.

INSTALLATION INSTRUCTIONS

Please choose a mounting place without any direct weather influences. Note that the amplifier generates heat so a well ventilated place is necessary. Follow instruction carefully to ensure the amplifier's full performance and reliability.

Keep the wire connections as short as possible with sufficient length in order to minimize power losses and provide a higher audio output of the system.

For safety reasons route all power and speaker wiring by using the existing wire channels.

To minimize damage to the cables, take care that they do not pass through sharp edged metal.

Lay all cables as far away as possible from the ignition cables, modules in the boot and under the key dashboard, as these create interference.

Add a fuse to the (+) power cable in a distance of not more than 30cm from the positive battery pole.

Keep the length of the power cable as short as possible. It is better to use power cables which are short and then longer speaker cables.

In order to reduce interference, please pay attention to the wiring instructions.

FEATURES

DA 2.175SQ

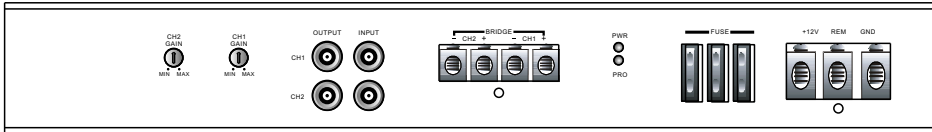

DA 4.120SQ

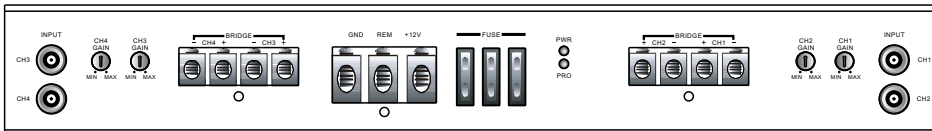

- ▶ Low Level Input
- ▶ Gain Control
- ▶ Short Circuit Protection
- ▶ Mosfet Power Supply
- ▶ Thermal Protection
- ▶ 2/4 Channel Power Amplifier
- ▶ LED Power and Protection Indicator

INTERFERENCE & NOISE

All cables are sources of interference and noise. The power cable and RCA audio cable are very prone to interference; the remote cables are less prone. There is of ten interference caused by the generator (piping), ignition (cracking) or other car electronic parts. Most of these problems can be eliminated by correct and careful cabling. In doing so, these are the following guidelines :

- ▶ Use only an RCA audio cable for the wiring between the amplifier and RCA output of the radio .
- ▶ Lay the signal, speaker and power cables separately with enough distance from one another and also from each other car cable. If not possible , you can lay the circuit and ground cable together with the serial cables. Audio and speaker cable should be as far away from these as possible. The REM cable to the automatic antenna output of the radio can be laid together with the signal cables.
- ▶ Avoid ground loops by laying the ground wiring of all components to a center point in a star-like way. You can find the best central point in measuring the voltage directly at the battery. Now compare this voltage value with the chosen ground point and the (+) terminal of the amplifier. If the measured voltage is only less different , you've found the correct central. Otherwise you have to look for another point. You should measure with the ignition being switched on and additionally switched on other electronics (rear window heating and light).
- ▶ If there are pickups from external electrical sources into the speaker cables, divide the core leads and twist them together.
- ▶ If there are noises from the car electronics. add a noise suppression choke to the power wiring .
- ▶ If there are humming noises, use thicker ground cables or add further ground cables to the chassis.
- ▶ To reduce contact resistance and bad and loose contacts, please tin the cable ends or use multi core cable ends, spade terminals or others. NI - Plated spade terminal are free of corrosion and have the lowest contact resistance.
- ▶ Should all these measures to without any success. the use of a ground loop isolator may solve the problem or problem or contact a certified car audio installer.

OPERATION

▶ **GND(-)=GROUND CONNECTION**

Connect the GND terminal to the chassis of your car and look for the best electrical & mechanical contact. In doing so, drill a hole in to the car chassis near the amplifier, then remove paint, dirt or any other substance from the ground point. After that fasten the cable end with added ring terminal by using a screw. Ensure that the ground connection is as short as possible and that the cable diameter is sufficient (min 4 mm").

▶ **+12V=POWER SUPPLY**

Connect the +12V terminal to the positive pole of the battery with a power cable and add a fuse to the power cable in a distance of not more than 30 cm from the battery. The power cables's diameter should be at least gauge 8 or larger.

▶ **REM(ON/OFF)REMOTE CONTROL**

Connect the REM terminal to the automatic antenna connector of your car radio. Now when turning on and off your car radio, the amplifier automatically switches ON and OFF. A cable diameter of 0.5mm² is sufficient.

▶ **FUSE**

The amplifier is equipped with a plug-in auto fuse protecting the set against faulty conditions .Do not use a fuse with a higher value and never bridge the fuse over, as this may lead to warranty being denied void.

HOW TO PROCEED IN CASE OF FAULTS

▶ **No Function:**

The connection cable is not connected correctly (=terminal BATT/GND /REM). Ensure that all connections, mechanical contacts ,and wire jacket have been removed. The fuse might be defective -pay attention to the correct value of a new fuse!

▶ **No Sound:**

Speaker cable or RCA plugs are not connected correctly.

▶ **No Sound /Red LED Protection Shines:**

The plus and minus wires of the speaker cable shorted, thus create a short circuit. If you use a 2 Ohm speaker in stereo mode, turn the gain control to " min " until the operation is free of trouble.

▶ **Poor Sound Quality (Distortions):**

The speakers are overloaded, therefore turn down the volume level and check the volume control positions.

▶ **No Stereo Sound And A Weak Bass:**

Left and right speaker cables (+) and (-) are out of phase.

PRECAUTIONS

- ▶ This unit is designed for negative ground 12V DC operation only.
- ▶ Avoid installing the amplifier where:
 - ▶ -It would be subject to high temperature , such as from direct sunlight or hot air from the heater.
 - It would be exposed to rain or moisture.
 - It would be subject to dust or dirt.
- ▶ If your car is parked in direct sunlight and there is a considerable rise in temperature inside the car, allow the amplifier to cool off before operation.
- ▶ When installing the unit horizontally, be sure not to cover the heatsink fins with the floor carpet.
- ▶ If this unit is placed too close to the car radio , an interference may occur. In this case, separate the amplifier from the car radio.
- ▶ This power amplifier employs a protection circuit to protect the transistors and speakers if the amplifier malfunctions. Do not attempt to test the protection circuits by covering the heatsink or connecting improper loads.
 - Do not use the amplifier with a weak auto battery as its optimum performance
- ▶ Depends on a normal battery supply voltage.
 - For safety reasons, keep the volume of your car audio system moderate so that
- ▶ You can still hear normal traffic sounds outside your car.

FUSE REPLACEMENT

If the fuse blows, check the power connection and replace the fuse. If the fuse blows again after replacement , there may be an internal malfunction . In this case, consult your dealer.

WARNING:

Use the specified fuse value. Using of a higher fuse value may cause serious damage.

PROTECTION CIRCUIT:

This amplifier is provided with a protection circuit which operates in the following cases when:

- ▶ The unit is overheated.
- ▶ The speaker terminals are short circuited.

POWER CONNECTION LEADS

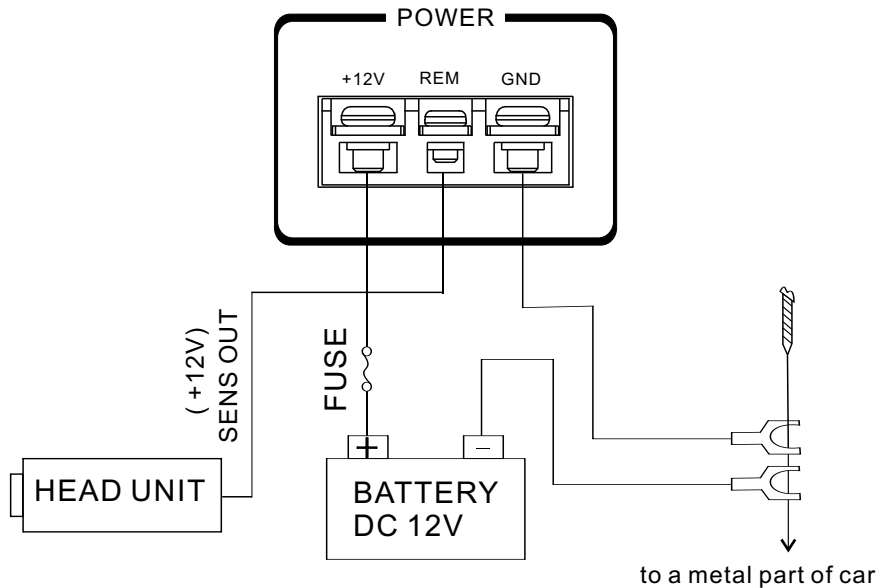

NOTES ON THE POWER SUPPLY :

- ▶ Connect the +12V power input lead only after all other leads have been connected .
- ▶ Be sure to connect the ground wire of the unit securely to a metal part of the car . A loose connection may cause a malfunction of the amplifier .
- ▶ REM: The unit is turned on by applying +12 Volts to this terminal. This terminal does not draw heavy current like the main Power Terminals so a thinner connecting wire is acceptable. Standard 18 GAUGE is fine and the standard color is blue. If the radio is equipped with a Power Antenna control wire, it can drive this terminal. If the Power Antenna wire is already in use, you can still splice into it . With this method, the unit will turn on automatically with the radio.
- ▶ Use the power supply lead with a fuse attached whose value is the same as original fuse inside the amplifier .
- ▶ Place the fuse in the power supply lead as close as possible to the car battery .
- ▶ During a full power operation. Maximum current will run through the system Therefore, make sure that the leads to be connected to the +12V and GND terminals of the unit respectively must be larger than 10-Gauge (AWG.10).

STEREO MODE

DA 2.175SQ

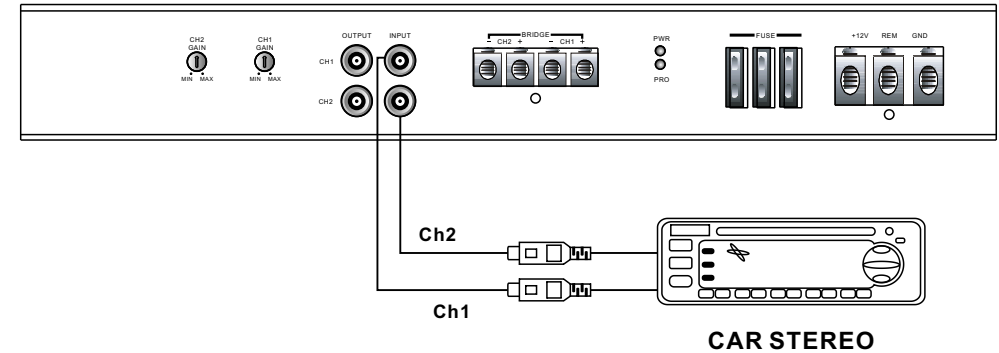

DA 4.120SQ

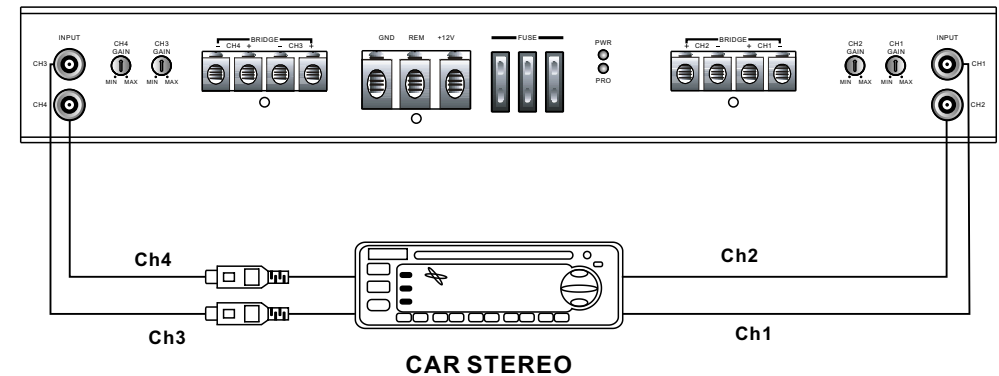

WIRING INSTRUCTIONS

▶ POWER CONNECTION

The battery terminal (+12V) must be connected directly to the positive terminal of the vehicle battery to provide an adequate voltage source and minimize noise. Connecting the battery terminal lead to any other point (such as the fuse block) will reduce the power output and may cause noise and distortion. Use only #8 gauge or thicker (smaller gauge #) wire for this lead and connect it to the terminal of the battery after all other wiring is completed.

▶ GROUND CONNECTION

The ground terminal (GND) connection is also critical to the correct operation of the amplifier. Use a wire of the same gauge as the power connection (#8 or thicker) and connect it between the ground terminal (GND) of the amplifier and a metal part of the vehicle close to the mounting location. This wire should be as short as possible and any paint or rust at the grounding point should be scraped away to provide a clean metal surface to which the end of the ground wire can be screwed or bolted.

▶ REMOTE TURN-ON CONNECTION

The amplifier is turned on by applying +12V to the remote turn-on terminal (REM). The wire lead to this terminal should be connected to the "Auto-Antenna" lead from the car stereo which will provide the +12V only when the car stereo is turned on. If the car stereo does not provide an "Auto-Antenna" lead, the remote turn-on lead may be wired to an "Accessory" or "Radio" terminal in the car's fuse block. This will turn the amplifier on and off with the ignition key, regardless of whether the car stereo is on or off. The remote turn-on lead does not carry large currents. So #20 gauge wire may be used for this application.

▶ SPEAKER CONNECTIONS

Depending on the type and number of speakers used with the amplifier, wired them to the speaker terminals as per the appropriate wiring diagram. For most applications #18 gauge wire should be used for the speaker leads but in no case thinner than #20 gauge. For leads in excess of 10 feet #16 gauge is recommended. When wiring the speakers, pay careful attention to the polarity of the terminals on the speakers and make sure they correspond to the polarity of the corresponding terminals on the amplifier. Do not ground any speaker leads to the chassis of the vehicle.

Caution: Use either the low-level or the high-level inputs on the amplifier. Do not use both input levels at the same time.

OPERATION

After the amplifier has been installed and all connections have been made carefully and securely, turn the radio on so that the amplifier is switched on automatically. After a short power-on period, the amplifier reaches its full performance.

Now turn up the volume slowly using the volume control of the radio. If there is no sound or only a distorted replay, switch off the radio immediately-the amplifier will also switch off automatically - and check if all connections have been made correctly.

▶ POWER=LED POWER INDICATOR

After the orderly connection of the three power terminals, the LED indicator shines green and goes out when is off.

▶ PROTECT =LED PROTECTION INDICATOR

This unit is equipped with an overload protection, immediately upon overloading (due to short circuit or much increased temperature) the overload protection is activated, and the red LED indicator is shining. Through this the amplifier is protected against damage. In case of the thermal protection a certain short cooling time must be allowed after which the amplifier automatically resumes operation.

▶ LEVEL CONTROL

The input level control allows the system to work well within a wide range of output level. Choose the adjustment in the way that you achieve a sound most possibly without any distortion. As a guideline the following procedure is recommended:

If you use several amplifiers, the adjustment has to be made for each set separately. Tune the volume control of your car radio to 2/3 of the maximum volume. Now turn the gain control of the amplifier from "Min" to "Max" direction until you can hear distortions. Then turn the level control a little back to "Min". The gain control adjustment is finished now.

Attention! If you use 2 Ohm speakers in stereo mode, turn the gain control to "Min" direction, until the operation is free of trouble.

SPEAKERS CONNECTIONS

DA 2.175SQ

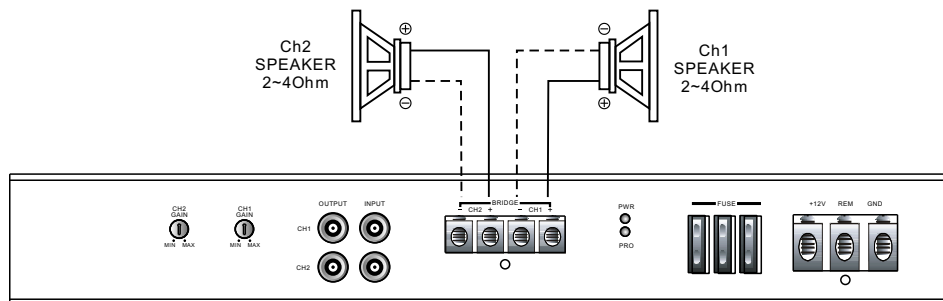

SPEAKERS BRIDGED MODE

DA 2.175SQ

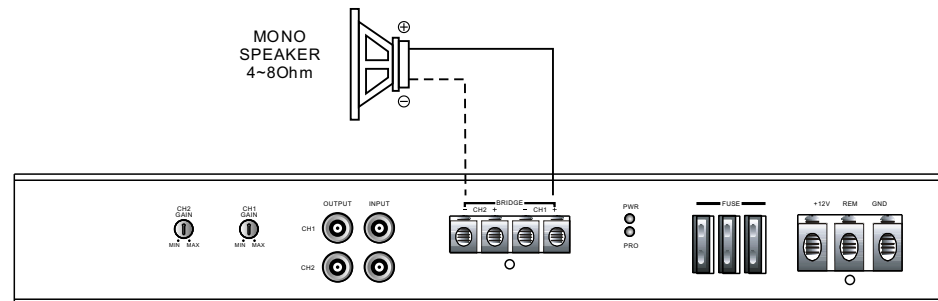

DA 4.120SQ

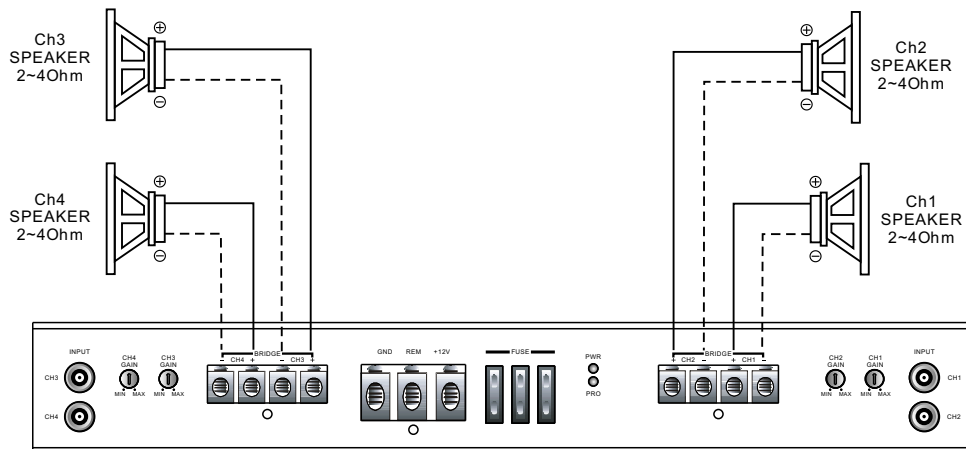

DA 4.120SQ

