

Dragster

DDM5000.1

DDM8000.1

DDM10500.1

DDM SERIES POWER AMPLIFIER

INSTALLATION AND OPERATION

Introduction

Thank you for purchasing a Dragster power amplifier of the DDM series. Year by year the technology designing car audio amplifiers has grown a lot and DDM Series is the ultimate production of Dragster range after more than 18 years from the DA and DB Series still used from thousand of customers every day. We consider top important to introduce the latest technologies offering you the absolute best sounding, combined with powerful outputs of course at a reasonable price.

We strongly recommend that your Dragster power amplifier be professionally installed, this will ensure that you will obtain the best possible performance from your amplifier, improving reliability and safety for you and your car.



WARNING: Use of this amplifier at extreme high volumes for extended periods of time may cause hearing loss and hearig damage. High volume levels while driving will impair your ability to hear necessary traffic sounds. While driving always keep your sound volume at reasonable levels.

Features

- **Thermal protection:** when the amplifier reaches and unsafe operating temperature of 90 degrees Celsius the amplifier will turn off. Once the amplifier cools down, simply reset the amplifier by its remote connection (turn the amplifier off and then on again once you have given the amplificator a change to cool down) and the ampwill once gain begin.
- **Speaker Short Circuit Protection:** should your speakers short circuit due to voice coil burn out, or should the amplifier sense an impedance too low to handle, the Protection LED will light, indicating a diagnostic condition. Turn off your system, disconnect one speaker at a time and try to determinate which speaker might be faulty.
- **Input Overload Protection:** the circuit will either shutdown the amplifier completely, or make the amplifier spurt on and off indicating that it is in a diagnostic condition. Turn the system off and reduce the gain on the amplifier or volume from your head unit, this should result in a corrected condition.
- **Bass Boost Control:** Dedicated control for low frequency ranges (40 to 120Hz), allowing you to regulate a desired frequency and control its gain (0 to + 12dB).

Before Installing

Read this manual carefully before installing the amplifier. You must follow the instructions for the product's installation and connections to guarantee optimal performance. If you have any questions, get in touch with us. Before using the amplifier, always follow these guidelines:

- Make sure the appliance is switched off before adding or removing any connections. This prevents possible damage tothe equipment connected to the amplifier;
- Keep all cables as far away as possible from the ignition cables, electronic injection modules and starter switch since they may cause noise interference;
- Always use good quality cables and connectors. This guarantees the sound's quality and fidelity;
- To avoid damaging the cables, make sure that they do not touch sharp metal edges.

Important: Use recommended fuse 30 centimeters from the battery as a safety precaution.

General Description

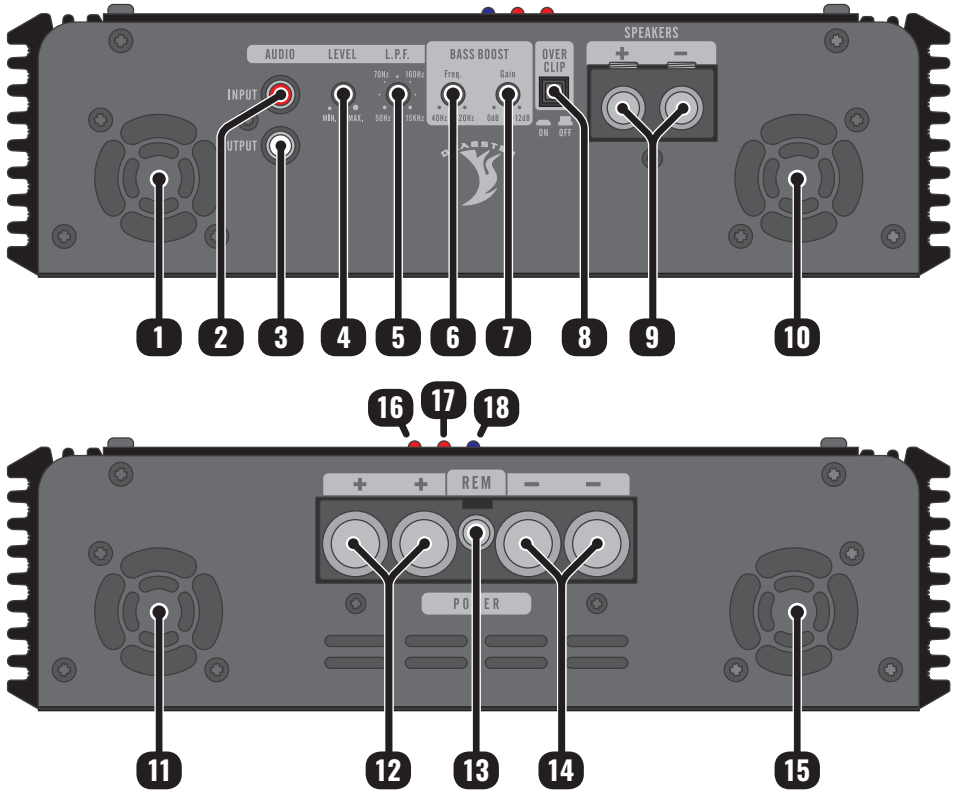

- 1 10 15 COOLER:** The fans work when the device is turned on. They provide device cooling.
- 2 INPUT:** This input should receive the signal through an RCA cable connected to the output of the receiver or player.
- 3 OUTPUT:** This output can be used optionally to play another amplifier, facilitating installation in multi-amplified systems.
- 4 LEVEL:** Controls the input signal level, allowing for proper control of any receiver or player. It can be regulated as the following:
 - A)** on the receiver or player, play any musical signal up to 80% volume.
(Ex: If the maximum volume on the player is 45 [100%], adjust to 36 [80%]).
 - B)** on the amplifier, beginning at the lowest LEVEL, gradually increase until the LED "OVER CLIP" begins to flash.
 - C)** slowly decrease the LEVEL until the LED "OVER CLIP" goes off.
- 5 L.P.F (LOW PASS FILTER):** Controls the low pass point for the speaker outputs. It is regulated from 50Hz to 15KHz).
- 6 FREQUENCY (BASS BOOST):** Adjustable control for boosting low frequency ranges from 40 to 120Hz.
- 7 GAIN (BASS BOOST):** Gain adjustment control from 0 to +12dB at the frequency set at bass boost.
- 8 OVER CLIP (ON/OFF):** With this key turned on, the LED "OVER CLIP" will light up at 15% more final capacity.

- 9 SPEAKER (OUTPUT):** This output is MONO. Be careful of maintaining the correct polarity of the connections between the speakers and check the minimum impedance of this output. Use cables with minimum gauge as specified for the purchased model.
- 10 VENTS:** Allows for the removal of warm air from the amplifier. In model **DDM5000.1**, this opening has a fan.
- 12 POSITIVE POWER SUPPLY +:** Connect the terminal **+** to the positive terminal of the battery (+12V). It is extremely important that a protective fuse or circuit breaker be used on this cable at a distance of 30 cm from the battery. The fuse or circuit breaker should be, at minimum, equal to the max current consumption value caused by playing musical signals (see technical specifications table).
- 13 REM (REMOTE CONTROL):** Connect the **REM** terminal to the electric antenna output of the receiver or player. This will cause the amplifier to turn on automatically when you turn on your receiver or player.
- 14 GROUND CONNECTION ⚡:** Connect the cable to the chassis of the vehicle. *Note: always connect the wire ⚡ of the player or other equipment to the same ground point.*
- 16 CLIP LED (RED):** This LED will light up when the signal begins to suffer distortion.
- 17 PROT LED (RED):** This LED will light up for the following reasons (see the diagnostic table on the back cover):
- A) Short circuit in the speakers
 - B) Excessive temperature
 - C) Low battery voltage
 - D) High battery voltage
- 18 POWER LED (BLUE):** This indicator LED will light up when it is activated by the remote control signal from the receiver or player.

Installing the Input Cables

In order to install the power supply, Use the appropriate cable as specified for the model chosen. The positive cable should come straight from the battery and have a fuse or protective breaker 30 cm from the battery. The negative cable should have the same gauge as the positive cable and be screwed to the chassis of the vehicle, being careful to avoid paint and rust. These may interfere with the flow of the electrical current and cause loss of power and interference in the sound.

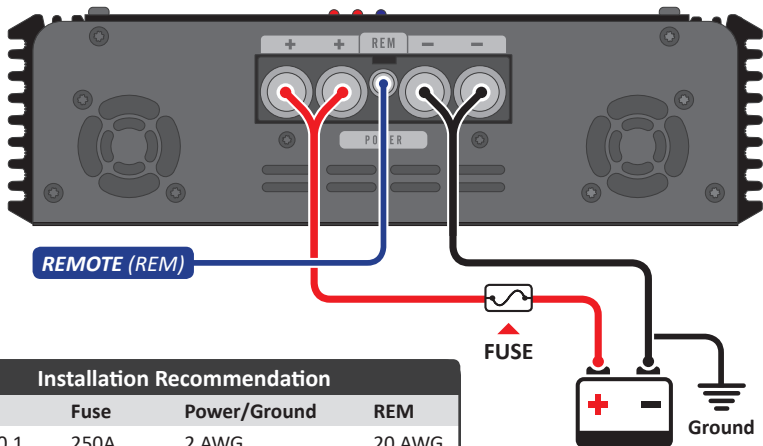

Installation Recommendation			
Model	Fuse	Power/Ground	REM
DDM5000.1	250A	2 AWG	20 AWG
DDM8000.1	400A	00 AWG	20 AWG
DDM10500.1	500A	00 AWG	20 AWG

ATTENTION: The use of a the fuse or breaker is required, since this amplifier has no internal fuses.

RECOMMENDED USE OF AUXILIARY BATTERY.

Installation Example for Speakers

The speaker cables should be polarized (marked) so that you can easily identify which is positive and which is negative. Keep the cables well insulated and avoid metal parts as these may damage the insulation. Check the minimum gauge of the installation cables for your model.

WITH 2 SPEAKERS
(2 x 2 Ohms)

Installation Speakers

DDM5000.1	8 AWG
DDM8000.1	8 AWG
DDM10500.1	7 AWG

WITH 4 SPEAKERS
(4 x 4 Ohms)

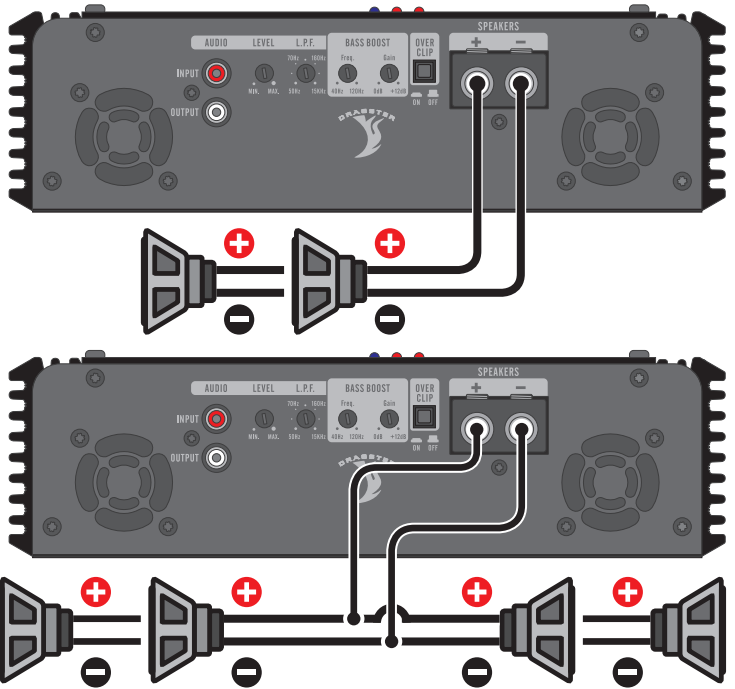

Troubleshooting

NO POWER:

- The power cables are not connected correctly (terminals +BAT, GND and REM). Verify that all the connections have electrical and mechanical contact.
- The fuse/circuit breakers are defective or blown. Replace them, making sure that the replacements are the correct ones!

NO SOUND:

- The speaker cables or RCA plugs are not connected correctly.
- Verify that the LEVEL control is at the lowest setting. Check the amplifier filter controls.

NO SOUND. RED ALERT PROT BLINKING:

- See "DIAGNOSTIC GUIDE"
- The speakers or cables are defective, so check speakers, cables and connections.

POOR SOUND QUALITY (DISTORTIONS):

- The speakers are overloaded. Decrease and readjust the volume level.

WEAK BASS:

- Speaker cables (+) and (-) are switched or the speaker is out of phase (see entry "INSTALLATION EXAMPLE FOR SPEAKERS"). Also check BASS control adjustment.

ENGINE, HORN, TURN SIGNAL, INTERFERENCE:

- Use suppressing/insulated cables on the spark plugs.

- Use capacitors on the alternator, horn and ignition.
 - Run the shielded input cable away from any other cables, as they are particularly prone to interference.
 - Install a separate power source (+12V) for the sound system. Use a fuse/circuit breaker 30 centimeters from the battery as the best precaution.
 - Ground the amplifier properly. Remove paint from the chassis at the selected point, and connect the wire using a grounded terminal. In order to prevent rust, insulate it with paint.
- Do not loop the ground. Avoid using multiple grounds. If possible, use a star connection, in which all the grounds run from a single point.

Technical Specifications

MODELS	DDM5000.1	DDM8000.1	DDM10500.1
Channels:	1	1	1
Power @ 14.4V - 1 Ohm (RMS):	5050W	8000W	10500W
Power @ 14.4V - 2 Ohms (RMS):	3230W	4500W	7000W
Min. Output Impedance:	1 Ohm	1 Ohm	1 Ohm
Input Impedance:	26K Ohms	25K Ohms	25K Ohms
Input Sensitivity:	0.2V	0.2V	0.2V
T.H.D:	≤ 10% THD	< 10% THD	≤ 10% THD
Signal to Noise Ratio:	>90dB	>90dB	>90dB
Freq. Resp. (-3dB) @ 8 Ohm:	10Hz ~ 15KHz	10Hz ~ 15KHz	10Hz ~ 15KHz
Crossover Low Pass:	50Hz ~ 15KHz	50Hz ~ 15KHz	50Hz ~ 15KHz
Bass Boost:	±12dB	±12dB	±12dB
Frequency Bass Boost:	40Hz ~ 120Hz	40Hz ~ 120Hz	40Hz ~ 120Hz
Over Clip (Power):	+15%	+15%	+15%
Power Supply:	9.5 ~ 15Vdc	9.5 ~ 15Vdc	9.5 ~ 15Vdc
Consumption Music:	4.1 ~ 250A	5.3 ~ 396 A	6.7 ~ 495A
Consumption BASS:	4.1 ~ 500A	5.3 ~ 750 A	6.7 ~ 990A
Dimensions (H x W x L):	76 x 258 x 315 mm	76 x 258 x 450 mm	76 x 258 x 515 mm
Weight:	4.3 Kg	6.4 Kg	7.8 Kg



The measured data are based on equipment from the our laboratory. Frequency reference of 1Khz with THD+N to ≤10% in impedances referring to the indicated in each measurement. The electronic components and the manufacturing process can present manufacturing variations, thus leading to a variation in the measurements made.







Any updates made in this manual will be available for consumers to consult without any charge on the brand's site. It is recommended that the updated manual be consulted whenever necessary.

Images contained in this manual are merely illustrative and may differ from the actual product.

Diagnost Guide

In the eventuality of any problems, the amplifier will power down and the **LED PROT (red)** light will begin to blink. Depending on the problem, the **LED PROT (red)** light will flash a certain number of times. The following table summarizes the diagnostics:

Number of Flashes	Problem	Solution
1 	Output short circuit or overload.	Check to make sure the speaker cables are pro-perly isolated. Verify minimum impedance.
2 	Overheating.	Make sure the equipment is installed in a well ventilated location.
3 	Low battery.	When used for long periods, the battery will run down. Recharge the battery.
4 	Battery overload or voltage greater than allowed.	Have the battery and/or alternator checked by a professional.

NOTE: In the event that the **RED LED (PROT)** light is flashing continuously, unplug the speakers and turn the equipment back on. If the problem persists, contact tech support.

Warranty Information

Dragster Audio Art provides its products with the necessary technical support to replace components, as well as the necessary work to repair any defects duly verified as being from its manufacture, within the warranty period and with their respective invoice.

WARRANTY TERMS AND CONDITIONS:

The warranty provided is for 2 (two) years against manufacturing defects. Its validity starts on the date of the invoice or, in case of warranty certificate, the date when it was issued.

To make use of the benefits of this warranty, you must present one of the following documents: the invoice or this certificate dated and stamped by the retailer or installer.

CASES THAT VOID THE WARRANTY:

1. Problems identified after 2 years of the invoice or of the warranty certificate (if completed) or 2 years from date of manufacture, in case you don't have any other document to prove when the product was bought.
2. Violation of seals, alteration or removal of the products serial or lot number.
3. If the product suffers misuse, careless accidents involving liquids, flames, fall or if it was installed in conditions contrary to the guidelines contained in the installation manual that accompanies the product.
4. Damages and changes in the circuit or adaptation of non-original parts.

IN CASE OF DOUBT OR IN ORDER TO ACCESS WARRANTY: www.dragsteraudio.it/contact